

2013 | 2014





# Qualität

## MADE IN GERMANY

Bei uns wird individuelle Beratung, kreative Produktentwicklung und Qualität groß geschrieben. Egal, was Sie verpacken möchten – wir stimmen alles perfekt auf Ihre Bedürfnisse ab. So wichtig kreative Ideen und eine qualitativ hochwertige Verpackung sind, so wichtig ist uns auch die weltweite und termingerechte Auslieferung der Produkte aus dem Hause Leser.

We attach great importance to personalised advice, creative product development and quality. No matter what you want to pack – we will coordinate everything according to your needs. As important as creative ideas and high quality packaging might be, the punctual and worldwide delivery of Leser products is equally important to us.

Chez nous, la consultation individuelle, le développement créatif de produits et la qualité sont capitaux. Quel que soit le produit que vous désirez emballer, nous agissons tout à la perfection en fonction de vos besoins. Les idées créatives et un emballage de très bonne qualité sont tout aussi importants que la livraison ponctuelle de vos produits par la maison Leser n'importe où dans le monde.

Para nosotros lo esencial es el asesoramiento individual, el desarrollo de productos creativos y la calidad. No importa lo que desee empaquetar: nos encargamos de adaptarlo todo de forma perfecta a sus necesidades. En la medida en que las ideas creativas y un embalaje de alto valor cualitativo son importantes, tan importante resulta para nosotros el suministro de los productos de la casa Leser a nivel mundial y cumpliendo fielmente los plazos.

Jochen Leser

Ralf Leser



quality qualite calidad



**ORIGINAL  
by LESER**





**Green PACK**  
by **LESER**



 **MADE IN GERMANY**

Schachteln aus Biokunststoff, einem nachwachsenden, pflanzlichen Rohstoff

Lift-off boxes made of bioplastic, a regrowing plant-derived raw material

Boîtes en bioplastique, une matière première végétale renouvelable

Cajas de bioplástico, materia prima de origen vegetal renovable

Biokunststoff | Bioplastic | Bioplastique | Bioplástico

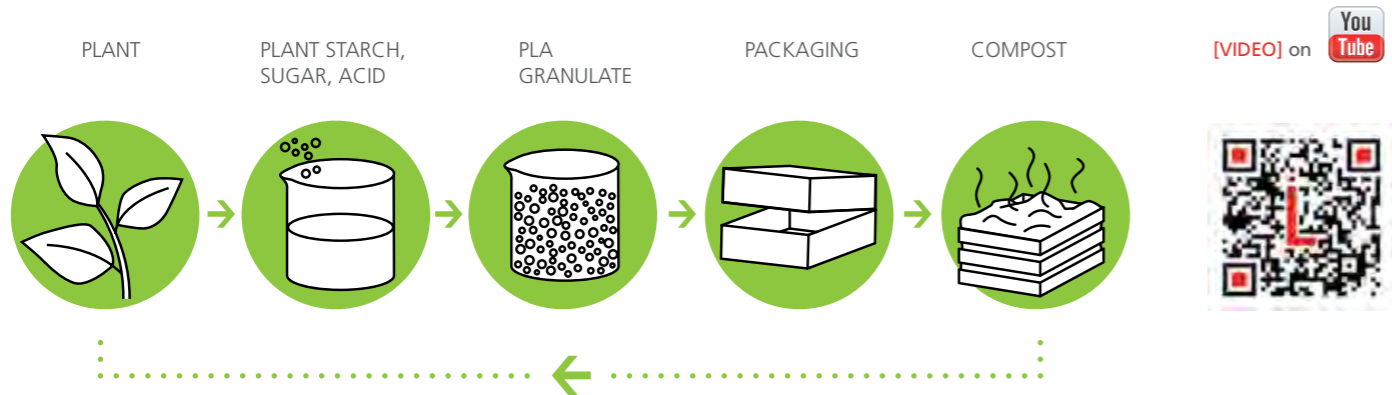























# CREATE YOUR STYLE

GESTALTEN SIE SELBST CRÉEZ VOTRE STYLE CREE SU ESTILO



# INHALT CONTENTS SOMMAIRE EL ÍNDICE

 <b>8-9</b> <small>MADE IN GERMANY</small> SERIE 0120 ELEMENT	 <b>28-29</b> <small>MADE IN GERMANY</small> SERIE 1560 EARTH	 <b>38-39</b> SERIE 5100 ELEGANCE
 <b>10-11</b> <small>MADE IN GERMANY</small> SERIE 0135 PICOT <b>NEW</b>	 <b>30-31</b> <small>MADE IN GERMANY</small> SERIE 1700 FUTURA	 <b>40-41</b> SERIE 5510 POESIE
 <b>12-13</b> SERIE 0230 PLAIN	 <b>32-33</b> <small>MADE IN GERMANY</small> SERIE 1750 FUTURA S	 <b>42-43</b> SERIE 5700 SHADOW
 <b>14-15</b> SERIE 0255 JOY	 <b>34-35</b> <small>MADE IN GERMANY</small> SERIE 2100 MODERN	 <b>44-45</b> SERIE 5850 SOFT TOUCH
 <b>16-17</b> SERIE 0270 FESTIVO	 <b>36-37</b> <small>MADE IN GERMANY</small> SERIE 2200 PRECIOUS	 <b>46-47</b> SERIE 5880 ALORS <b>NEW</b>
 <b>18-19</b> SERIE 0271 SURPRISE		 <b>48-49</b> SERIE 5950 FRAME
 <b>20-21</b> SERIE 0280 CROCO		 <b>50-51</b> SERIE 6400 REDWOOD
 <b>22-23</b> SERIE 0730 FUN		 <b>60-61</b> SERIE 8050 / 9909 ZIPPER <b>NEW</b>
 <b>24-25</b> SERIE 0740 LAGUNA		
 <b>26-27</b> SERIE 0760 VARIO		

DECORS



DECOR 1  
VALENTINE



DECOR 2  
FLOWER

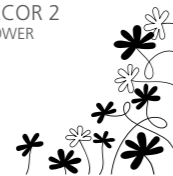

DECOR 3  
HEART



DECOR 4  
CLASSIC



DECOR 5  
ICE



DECOR 6  
SPLASH



DECOR 7  
STRIPES



DECOR 8  
MODERN



 <b>52-55</b> Uhrenbeweger / Uhrenetui Watchwinder / Watches Remontoir / Montres Devanadera / Relojes	 <b>62-65</b> Tragetaschen / Accessoires Paper Bag / Accessoires Sacs Papier / Accessoires Bolsas Papel / Accessoires	 <b>76-77</b> Lager- und Vorlagetablets Trays for storage & presentation Cuvettes de rangement et de présentation Bandejas de presentación
 <b>56-57</b> Trauringe Wedding rings Alliances Anillos	 <b>66-71</b> Etalagenserien Displays Décoration vitrine Taqueria	 <b>78-80</b> Möbel-Einbau-Systeme Furniture systems Meubles de rangement Sistemas de muebles
 <b>58-59</b> Fixboxen / Schmuckbeutel Fix Boxes / Jewellery Bags Boîtes cartonnées / Pochettes de bijoux Fix Box / Sobres papel	 <b>72-75</b> Ringständer / Preisauszeichnungen Ring displays / Pricing system Supports de bagues / Affichage de prix Soportes sortijas / Numeraciones para montar precios	

# SERIE 0120 ELEMENT

Kartonschachteln mit Watte | Lift-off cardboard boxes with cotton inside  
Boîtes en carton avec intérieur ouate | Cajas de cartón con guata



0120 66 UNI   
60 x 60 x 22 mm



0120 39   
158 x 158 x 25 mm



0120 44 UNI   
40 x 40 x 18 mm



0120 46   
120 x 90 x 20 mm



0120 88 UNI   
80 x 80 x 22 mm



0120 89 UNI  
85 x 85 x 60 mm



FARBEN COLOURS COULEURS COLORES



002003

Innen  
interior  
intérieur

**Green PACK**  
by **LESER**

NEW · NOUVEAU · NUEVO

MADE IN GERMANY

# SERIE 0135 PICOT

Kartonschachteln mit Schaumstoffeinlage | Lift-off cardboard boxes with foam pad inside  
Boîtes en carton avec intérieur mousse floquée | Cajas de cartón con interior de espuma



0135 21   
40 x 45 x 30 mm



0135 39   
158 x 158 x 25 mm



0135 44   
40 x 40 x 18 mm



0135 66   
60 x 60 x 22 mm



0135 89   
89 x 85 x 60 mm



0135 88   
80 x 80 x 22 mm



0135 02   
255 x 50 x 20 mm



FARBEN COLOURS COULEURS COLORES



Abdeckscham  
Foam pad  
Mousse de protection  
Espuma para tapar



049001



073003



204001



Innen  
interior  
intérieur

## SPECIAL



TRAGETASCHEN	62/63
PAPER BAG	62/63
SAC PAPIER	62/63
BOLSAS PAPEL	62/63



NEW

# SERIE 0230 PLAIN

Kartonschachteln mit Schaumstoffeinlage | Lift-off cardboard boxes with foam pad inside  
Boîtes en carton avec intérieur mousse floquée | Cajas de cartón con interior de espuma



0230 88 UNI   
80 x 80 x 22 mm



0230 39    
158 x 158 x 25 mm



0230 02 UNI   
255 x 50 x 20 mm



0230 21     
40 x 45 x 30 mm



0230 44 UNI   
40 x 40 x 18 mm



0230 66 UNI    
60 x 60 x 22 mm



## FARBEN COLOURS COULEURS COLORES



**NEW**



## SPECIAL

TRAGETASCHEN	62/63
PAPER BAG	62/63
SAC PAPIER	62/63
BOLSAS PAPEL	62/63







0255 22     
50 x 50 x 35 mm



0255 88 UNI   
80 x 80 x 25 mm





0255 66 UNI    
60 x 60 x 25 mm

# SERIE 0255 JOY

Kartonschachteln mit Schaumstoffeinlage und zusätzlicher Schaumstoffabdeckung  
Lift-off cardboard boxes with foam pad inside and additional unflocked foam pad for lid  
Boîtes en carton avec intérieur mousse floquée avec découpes et mousse de protection supplémentaire  
Cajas de cartón con interior de espuma, con cortes y espuma adicional para tapar



0255 02 UNI    
255 x 50 x 25 mm

0255 39    
158 x 158 x 25 mm



## FARBEN COLOURS COULEURS COLORES

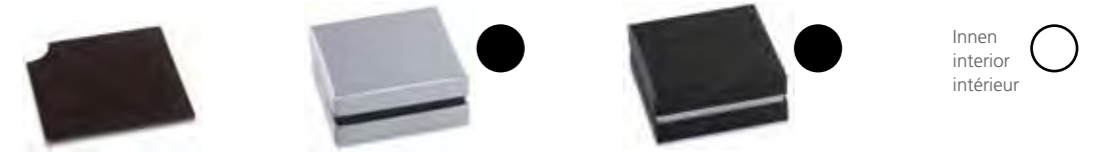

Abdeckschaum  
Foam pad  
Mousse de protection  
Espuma para tapar

179001

151001

Innen  
interior  
intérieur



### SPECIAL

TRAGETASCHEN	62/63
PAPER BAG	62/63
SAC PAPIER	62/63
BOLSAS PAPEL	62/63





# SERIE 0270 FESTIVO\*

Kartonschachteln mit Schaumstoffeinlage | Lift-off cardboard boxes with foam pad inside  
Boîtes en carton avec intérieur mousse floquée | Cajas de cartón con interior de espuma



0270 88 UNI   
80 x 80 x 22 mm





0270 66 UNI    
60 x 60 x 22 mm



0270 21    
50 x 50 x 30 mm



0270 39    
158 x 158 x 25 mm



## FARBEN COLOURS COULEURS COLORES

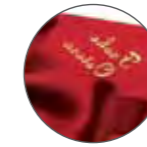
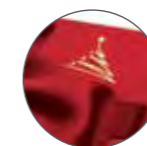

004001

### SPECIAL

FIXBOXEN	58
FIXBOXEN	58
BOÎTES CARTONNÉES	58
FIX BOXES	58



Innen  
interior  
intérieur

# SERIE 0271 SURPRISE

Kartonschachteln mit Schaumstoffeinlage | Lift-off cardboard boxes with foam pad inside  
Boîtes en carton avec intérieur mousse floquée | Cajas de cartón con interior de espuma



0271 88 UNI  
80 x 80 x 22 mm

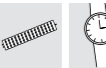

0271 12   
240 x 50 x 20 mm



0271 66 UNI   
60 x 60 x 30 mm



0271 39   
158 x 158 x 25 mm



FARBEN COLOURS COULEURS COLORES



Innen  
interior  
intérieur

## SPECIAL

TRAGETASCHEN	62/63
PAPER BAG	62/63
SAC PAPIER	62/63
BOLSAS PAPEL	62/63





0280 66 UNI   
60 x 60 x 26 mm



0280 21   
50 x 50 x 35 mm



0280 40   
180 x 180 x 32 mm

# SERIE 0280 CROCO

Überzogene Kartonschachteln mit Schaumstoffeinlage und zusätzlicher Schaumstoffabdeckung  
Covered cardboard boxes with foam pad inside and additional unflocked foam pad for lid  
Écrins en carton recouvertes avec intérieur mousse floquée avec découpes et mousse de protection supplémentaire  
Cajas de cartón con interior de espuma y espuma adicional para tapar



**NEW**



0280 89 UNI   
85 x 85 x 60 mm



0280 88 UNI   
80 x 80 x 26 mm



FARBEN COLOURS COULEURS COLORES



Abdeckschaum  
Foam pad  
Mousse de protection  
Espuma para tapar



001001

Innen  
interior  
intérieur



**SPECIAL**

TRAGETASCHEN	62/63
PAPER BAG	62/63
SAC PAPIER	62/63
BOLSAS PAPEL	62/63





**NEW**



0730 21     
50 x 50 x 35 mm



0730 02 **UNI**    
255 x 50 x 25 mm



0730 66 **UNI**  
60 x 60 x 25 mm



0730 39    
158 x 158 x 25 mm



0730 88 **UNI**   
80 x 80 x 25 mm



# SERIE 0730 FUN

Kartonetuis mit Schaumstoffeinlage und zusätzlicher Schaumstoffabdeckung  
Cardboard boxes with foam pad inside and additional unflocked foam pad for lid  
Écrins en carton avec intérieur mousse floquée avec découpes et mousse de protection supplémentaire  
Estuches de cartón con interior de espuma, con cortes y espuma adicional para tapar

## FARBEN COLOURS COULEURS COLORES



Abdeckschaum  
Foam pad  
Mousse de protection  
Espuma para tapar

191005

071001

073003

Innen  
interior  
intérieur

## SPECIAL





TRAGETASCHEN	62/63
PAPER BAG	62/63
SAC PAPIER	62/63
BOLSAS PAPEL	62/63



# SERIE 0740 LAGUNA

Kartonetuis mit Schaumstoffwendeinlage und Einschlagtuch | Cardboard boxes with foam pad (one face black, one face white) and velvet cloth inside  
Écrins en carton avec intérieur mousse floquée noire et blanche et enveloppe | Estuches de cartón con interior de espuma doble y tejido



0740 29    
76 x 53 x 22 mm



0740 21     
40 x 45 x 30 mm



Schaumstoffwendeinlage  
foam pad (one face black, one face white)  
mousse floquée noire et blanche  
espuma doble



0740 66 **UNI**    
60 x 60 x 22 mm

0740 88 **UNI**   
85 x 85 x 22 mm



**NEW**

Klotzeinlage  
Klotzeinlage  
Klotzeinlage  
Klotzeinlage



0740 37    
158 x 158 x 24 mm



FARBEN COLOURS COULEURS COLORES



071001

Innen  
interior  
intérieur



## SPECIAL



TRAGETASCHEN	62/63
PAPER BAG	62/63
SAC PAPIER	62/63
BOLSAS PAPEL	62/63



# SERIE 0760 VARIO

Kartonetuis mit Schaumstoffwendeinlage und Einschlagtuch | Cardboard boxes with foam pad (one face black, one face white) and waffle cloth inside  
 Écrins en carton avec mousse floquée noire et blanche et enveloppe | Estuches de cartón con interior de espuma doble cara y tejido



0760 29    
 76 x 53 x 26 mm



0760 21     
 76 x 45 x 30 mm



Schaumstoffwendeinlage  
 foam pad (one face black, one face white)  
 mousse floquée noire et blanche  
 espuma doble





0760 88 UNI   
 84 x 87 x 22 mm



0760 39    
 157 x 161 x 25 mm



0760 66 UNI    
 59 x 62 x 22 mm



0760 02 UNI   
 239 x 53 x 22 mm



FARBEN COLOURS COULEURS COLORES



047001



001001

Innen  
 interior  
 intérieur 





**Green PACK**  
by **LESER**

NEW · NOUVEAU · NUEVO



# SERIE 1560 EARTH

Schachteln aus Biokunststoff, einem nachwachsenden, pflanzlichen Rohstoff  
 Lift-off boxes made of bioplastic, a regrowing plant-derived raw material  
 Boîtes en bioplastique, une matière première végétale renouvelable  
 Cajas de bioplástico, materia prima de origen vegetal renovable



1560 66 UNI   
60 x 60 x 22 mm



1560 21   
40 x 45 x 30 mm



1560 44 UNI   
40 x 40 x 18 mm



1560 37   
158 x 158 x 25 mm



1560 88 UNI   
80 x 80 x 22 mm



FARBEN COLOURS COULEURS COLORES





# SERIE 1700 FUTURA

Kunststoffschachteln mit Watte | Lift-off plastic boxes with cotton inside  
Boîtes plastiques avec intérieur ouate | Cajas de plástico con guata



1700 44 UNI   
40 x 40 x 16 mm



1700 66 UNI    
60 x 60 x 20 mm



1700 88 UNI   
80 x 80 x 22 mm



1700 21     
42 x 42 x 33 mm



1700 37    
160 x 160 x 25 mm

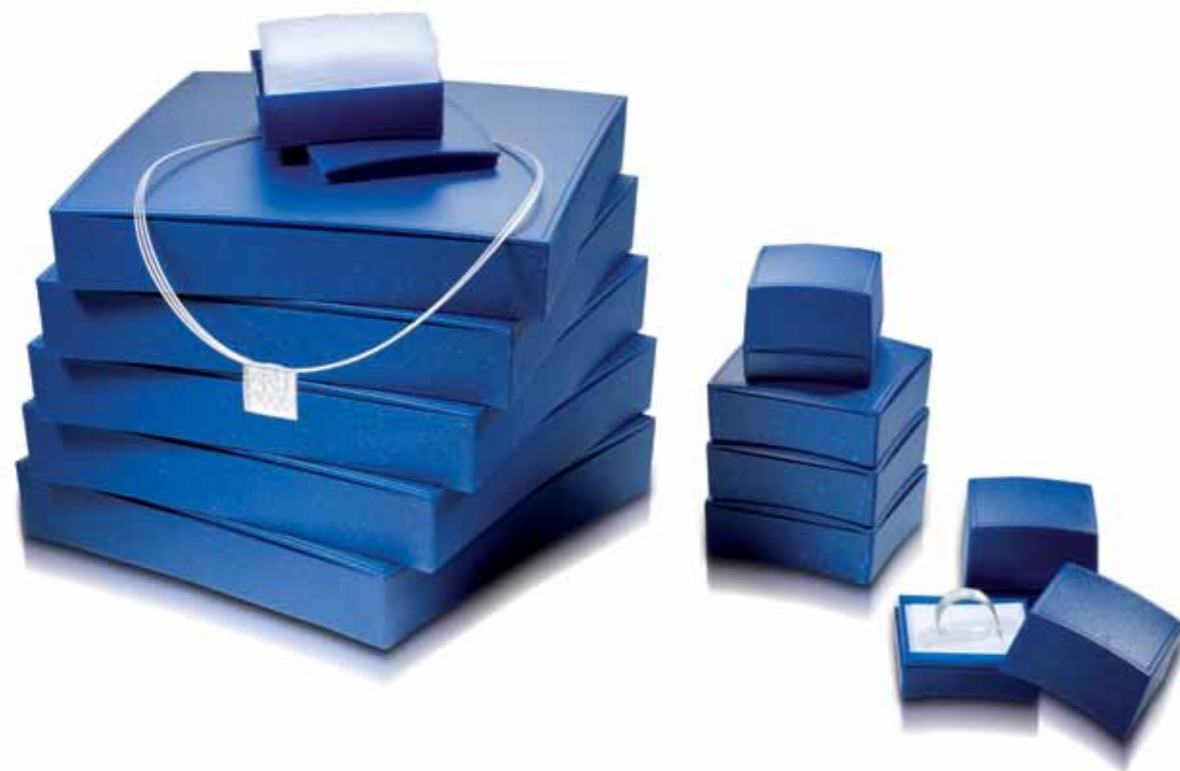

## FARBEN COLOURS COULEURS COLORES



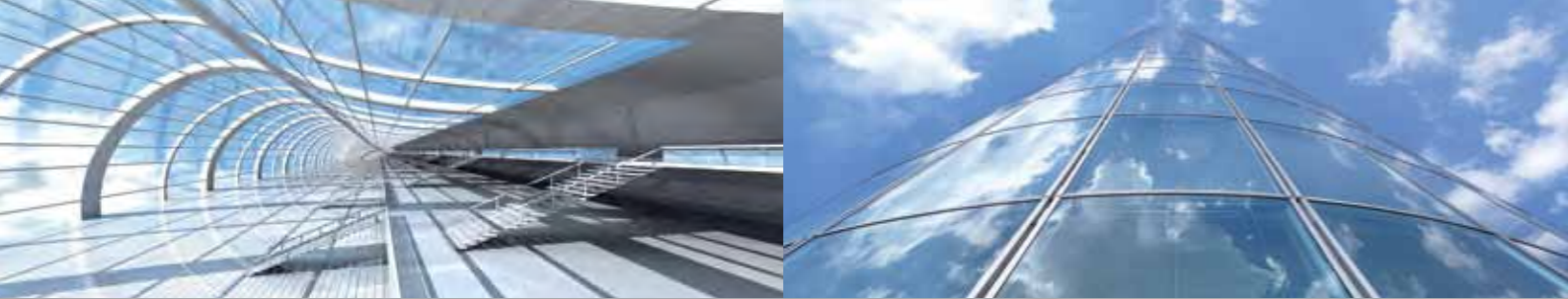

# SERIE 1750 FUTURA S

Kunststoffschachteln mit Schaumstoffeinlage | Lift-off plastic boxes with foam pad inside  
 Boîtes plastiques avec intérieur mousse floquée | Cajas de plástico con espuma



1750 21  
42 x 42 x 33 mm



1750 03 UNI  
208 x 30 x 18 mm



1750 02 UNI  
242 x 46 x 17 mm



1750 66 UNI  
60 x 60 x 20 mm



1750 44 UNI  
40 x 40 x 16 mm







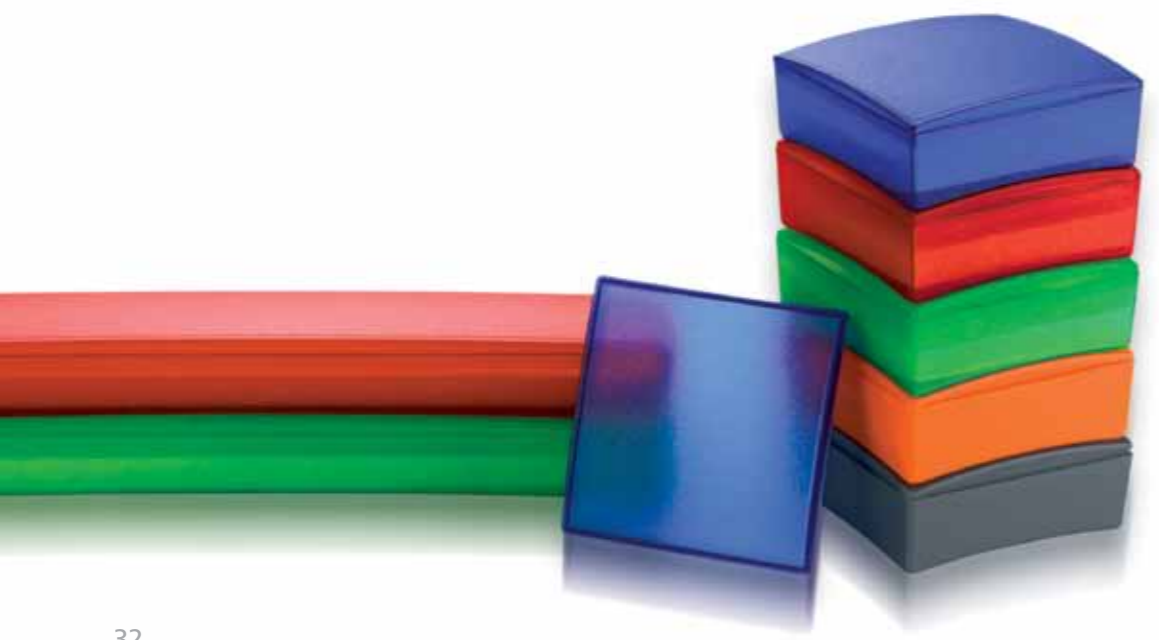

1750 88 UNI  
80 x 80 x 22 mm

1750 37  
160 x 160 x 25 mm

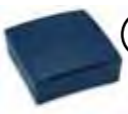

FARBEN COLOURS COULEURS COLORES

				
T R A N S L	U T I O N			
060003	061003	062003	118003	
				
038003	028001	156001		

# SERIE 2100 MODERN

Kunststoffetuis mit Schaumstoffeinlage | Hinged plastic boxes with foam pad inside  
Écrins plastiques avec intérieur mousse floquée | Estuches de plástico con espuma



2100 88 UNI   
80 x 80 x 21 mm



2100 08    
55 x 83 x 20 mm





2100 21     
40 x 45 x 32 mm



2100 07    
60 x 60 x 18 mm



2100 20    
215 x 90 x 20 mm



2100 37    
160 x 185 x 22 mm



2100 44 UNI   
45 x 45 x 18 mm



2100 03 UNI   
215 x 35 x 18 mm



FARBEN COLOURS COULEURS COLORES



001001



044003



Innen  
interior  
intérieur

# SERIE 2200 PRECIOUS

Kunststoffetuis mit Schaumstoffeinlage | Hinged plastic boxes with foam pad inside  
Écrins plastiques avec intérieur mousse floquée | Estuches de plástico con espuma



2200 21   
40 x 45 x 32 mm



2200 09   
80 x 80 x 21 mm



2200 07   
60 x 60 x 18 mm

2200 44 **UNI**   
45 x 45 x 18 mm



2200 03 **UNI**   
215 x 35 x 18 mm



2200 37   
160 x 185 x 22 mm



2200 02 **UNI**   
243 x 50 x 18 mm



2200 08   
55 x 83 x 20 mm

FARBEN COLOURS COULEURS COLORES



068003\*



042003



043001

Innen  
interior  
intérieur

# SERIE 5100 ELEGANCE

Hochwertig überzogene Etuis mit schmuckbezogener Einlage | Boxes covered with up-market Skivertex and pad for jewellery inside  
 Écrins design de luxe recouverts de Skivertex avec intérieur de luxe | Estuches forradas de polipiel de alta calidad con interior de gran valor





5100 07   
60 x 60 x 22 mm



5100 09   
80 x 80 x 22 mm



5100 39   
165 x 165 x 25 mm

5100 29   
50 x 55 x 32 mm



5100 23   
40 x 45 x 30 mm

FARBEN COLOURS COULEURS COLORES



004003





001001

Innen  
interior  
intérieur

# SERIE 5510 POESIE

Hochwertig überzogene Etuis mit Nappa-Leder-Imitat und schmuckbezogener Einlage  
 Premium boxes covered with artificial leather and pad for jewellery inside  
 Écrins design de luxe recouvert d'imitation Nappa avec intérieur de luxe  
 Estuches forrados de imitación de piel de alta calidad, con interior de gran valor

5510 09    
 82 x 82 x 27 mm



5510 39    
 165 x 159 x 29 mm



5510 29   
 69 x 41 x 31 mm

5510 16  



5510 03   
 216 x 46 x 18 mm



5510 25   
 42 x 41 x 32 mm



5510 64   
 59 x 59 x 20 mm

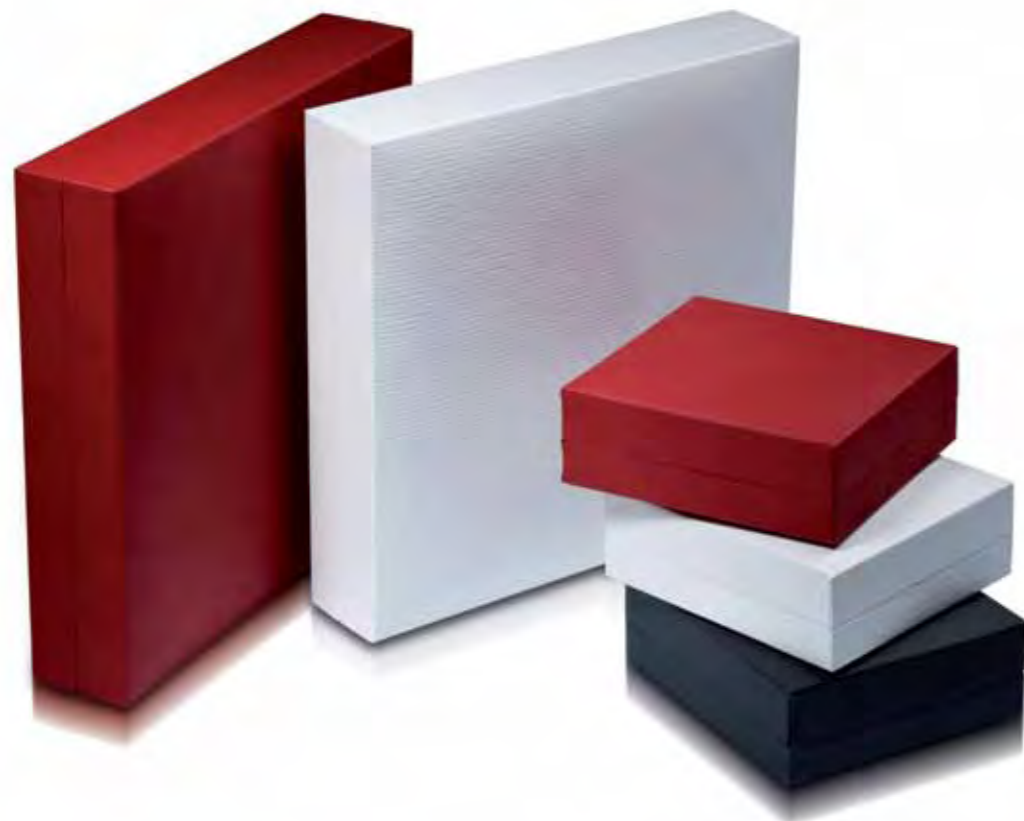

FARBEN COLOURS COULEURS COLORES



Innen  
interior  
intérieur



# SERIE 5700 SHADOW

Überzogene Kunststoffschachtel mit schmuckbezogener Einlage | covered plastic box with apad for jewellery inside  
 Ecrins plastiques recouverts avec intérieur adapté | Estuches forradas de polipiel de alta calidad con interior de gran valor



5700 88 UNI   
 72 x 72 x 45 mm



5700 02   
 229 x 39 x 27 mm



5700 39   
 189 x 189 x 37 mm



5700 89 UNI  
 90 x 90 x 66 mm



FARBEN COLOURS COULEURS COLORES



001001

Innen  
 interior  
 intérieur 

# SERIE 5850 SOFT TOUCH

Hochwertig überzogene Etuis mit Nappa-Leder-Imitat und schmuckbezogener Einlage  
 Premium boxes covered with artificial leather and pad for jewellery inside  
 Écrins design de luxe recouvert d'imitation Nappa avec intérieur de luxe  
 Estuches forrados de imitación de piel de alta calidad, con interior de gran valor



5850 03   
 213 x 42 x 24 mm





5850 09    
 80 x 80 x 26 mm



5850 25   
 45 x 45 x 40 mm



5850 29    
 62 x 40 x 25 mm





5850 64   
 54 x 58 x 21 mm



5850 16    
 45 x 45 x 26 mm



5850 39    
 165 x 177 x 29 mm



FARBEN COLOURS COULEURS COLORES



001001



005010



Innen  
 interior  
 intérieur 



NEW · NOUVEAU · NUEVO

# SERIE 5880 ALORS

Hochwertig überzogene Etuis mit Velours-Leder-Imitat und schmuckbezogener Einlage inkl. schwarzem Umkarton  
 Premium boxes covered with artificial velours and pad for jewellery, inclusive black covering box  
 Écrins design de luxe recouverts d'imitation velours avec intérieur de luxe et suremballage noir  
 Estuches forradas de imitación de piel de alta calidad, con interior de gran valor, incluso caja de cartón negro



5880 03   
 213 x 42 x 24 mm



5880 09   
 80 x 80 x 26 mm



5880 25   
 45 x 45 x 40 mm



5880 64   
 54 x 58 x 21 mm



5880 29   
 62 x 40 x 25 mm



5880 39   
 165 x 177 x 29 mm

FARBEN COLOURS COULEURS COLORES



007007

Innen  
 interior  
 intérieur

## SPECIAL

UMKARTON  
 COVERING BOX  
 SUREMBALLAGE  
 CAJA DE CARTÓN





5950 40 UNI   
180 x 230 x 35 mm



5950 03   
220 x 40 x 25 mm



5950 02   
265 x 60 x 25 mm



5950 44 UNI  
50 x 50 x 25 mm



5950 66 UNI  
70 x 70 x 25 mm

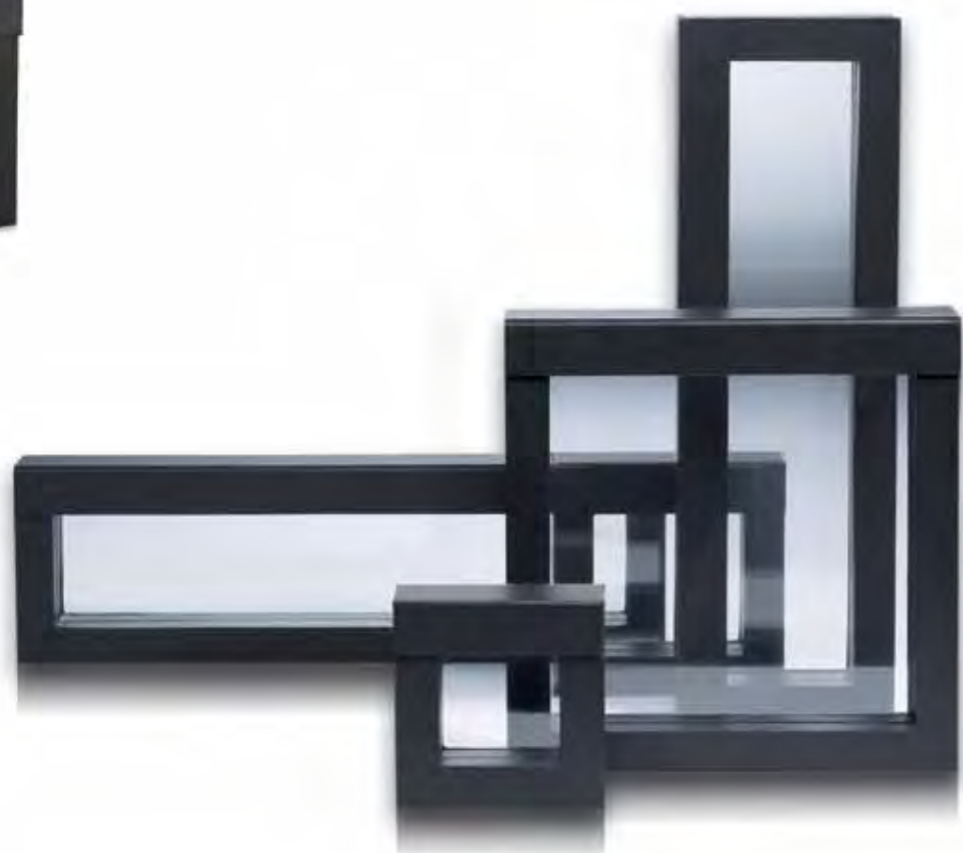

# SERIE 5950 FRAME

Überzogene Kunststoff-Rahmenetuis mit Siliconmembran | Covered frame boxes with silicone membrane  
Écrin recouvert forme cadre avec membrane silicone | Estuche forrado, en forma de cuadro, y membrana central de silicona

**NEW**



5950 20 UNI   
173 x 123 x 28 mm

**NEW**



Charmseinlage  
Pad for charms  
Cousinet pour charms  
Interior para charms

9000 47



5950 36   
150 x 150 x 25 mm



5950 88 UNI  
100 x 100 x 25 mm

FARBEN COLOURS COULEURS COLORES

**NEW**



00100



00300



001900



003900

Innen  
interior  
intérieur



# SERIE 6400 REDWOOD\*

Holzetais mit hochwertiger schmuckbezogener Einlage | Wooden boxes with top quality interior  
Écrins en bois avec coussinets de luxe à l'intérieur | Estuches de madera con interior de alta calidad



6400 06   
95 x 95 x 69 mm



6400 16    
48 x 39 x 23 mm



6400 02 **UNI**   
220 x 36 x 20 mm



6400 23   
51 x 48 x 36 mm



6400 39    
166 x 166 x 27 mm



6400 64   
64 x 64 x 28 mm



6400 09    
87 x 84 x 27 mm



6400 30   
62 x 39 x 23 mm

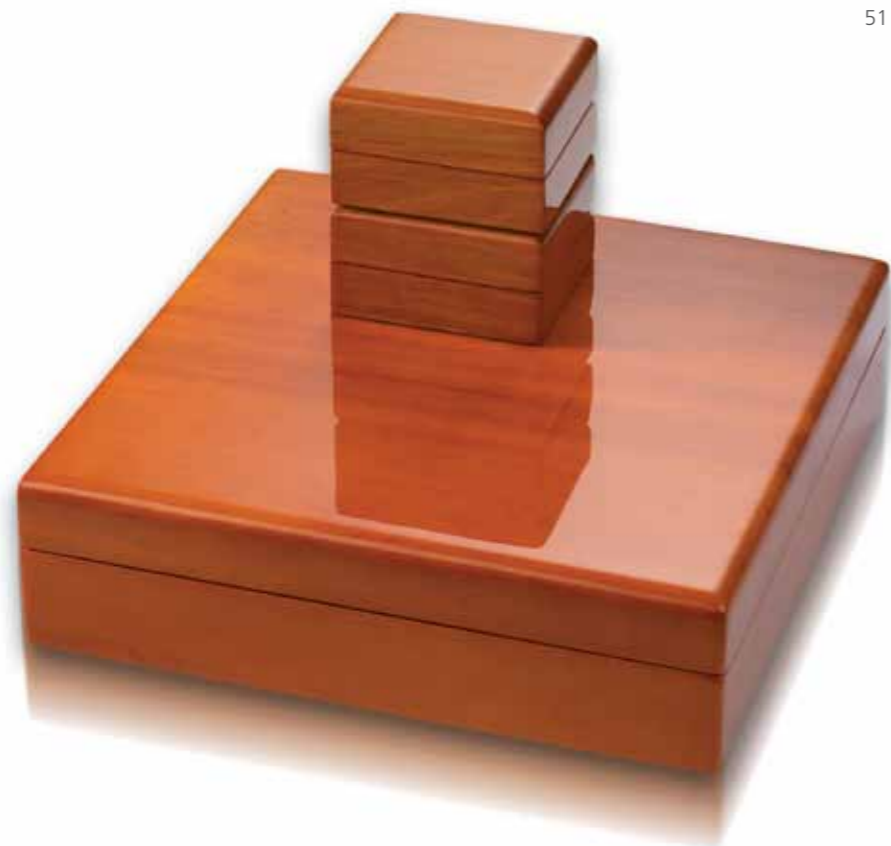

FARBEN COLOURS COULEURS COLORES



005010

Innen  
interior  
intérieur



# UHREN WATCHES MONTRES RELOJES

## UHRENBEWEGER WATCHWINDER REMONTOIR DEVANADERA

**NEW**

Hochwertiges Lederetui mit Glasscheibe  
 Noble leather case with glass window  
 Écrin en cuir de haute qualité avec vitre  
 Estuches de piel de gran valor von cristal



8051 41



8051 12



8051 01



8051 22



8051 31



9905 01.111001



6400 06.005010



6400 06.111001



9905 01.115003



0230 89 UNI   
85 x 85 x 60 mm



TRAURINGE WEDDING RINGS ALLIANCES ANILLOS



5300 06.004003



5300 05.004003



1900 08.075003



1900 21.075003



2100 30.003003



5100 30.003003



5900 29.001001



5900 29.003003



5950 66



9000 74

9000 73



0275 28.010010



5300 60.001001



5300 61.001001



5300 60.003003



5300 61.003003



9200 01–9200 03



9200 03  
115 x 170 mm



9200 01  
75 x 105 mm

9200 02  
105 x 141 mm



9350 47.189000  
198 x 140 x 40 mm



9350 43.189000  
158 x 110 x 38 mm



9350 25  
268 x 90 x 35 mm



9350 22  
71 x 74 x 22 mm



9350 23  
78 x 100 x 37 mm



9350 27  
105 x 135 x 45 mm



9300 52  
80 x 20 mm

NEW



9300 52  
80 x 20 mm



9310 42  
Ø 85 mm



9300 01  
78 x 86 mm



9300 02  
95 x 109 mm



9310 41  
Ø 65 mm

9310 40  
Ø 50 mm



9300 01–9300 04\*



9300 03  
112 x 125 mm



9300 04  
141 x 147 mm

SCHMUCKBEUTEL JEWELLERY BAGS BOURSES SUÉDINES BOLSAS PARA JOYERÍA



9300 71.153000\*  
70 x 85 mm



9300 72.153000\*  
100 x 130 mm



9310 75.047000  
Ø 75 mm



9310 75.048000  
Ø 75 mm



9300 72 – 9300 73\*



9300 73.153000\*  
130 x 180 mm



Präsentationselement  
Stand for presentation  
Élément de présentation  
Elemento de presentación

**50 mm: 9935 41.921000**  
50 x 12 x 50 mm

**125 mm: 9935 42.921000**  
50 x 12 x 125 mm

**200 mm: 9935 43.921000**  
50 x 12 x 200 mm

Bodenplatte  
Bottom plate  
Plateau de sond  
Placa de base

**9935 40.921000**  
400 x 200 x 18 mm

SPECIAL SIZE



NEW

**5500 40.003003**  
183 x 178 x 40 mm



**8050 51.115115**  
166 x 112 x 36 mm



**0250 40.001001**  
190 x 190 x 35 mm

NEW



**9909 52.099001**

Set à 6 farblich sortiert  
Set 6 pieces colour-assorted  
Set à 6 pièces (assortiment de 3 couleurs)  
Set a 6 piezas surtido de 3 colores





TRAGETASCHEN

PAPER BAG SAC PAPIER BOLSAS PAPEL



9250 53  
130 x 60 x 190 mm

9250 55  
195 x 80 x 265 mm

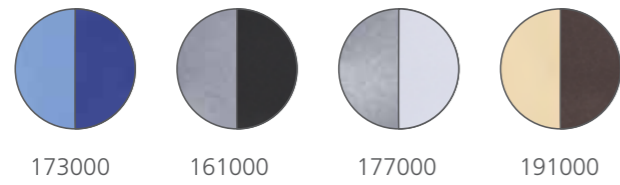

173000 161000 177000 191000



9250 53  
130 x 60 x 190 mm

9250 55  
195 x 80 x 265 mm



103000 111000 154000



NEW

9250 57.205000  
230 x 100 x 300 mm



Green PACK  
by LESER

NEW

9260 55.003000  
195 x 80 x 265 mm



Green PACK  
by LESER

NEW

9260 55.157000  
195 x 80 x 265 mm



9250 57.001000  
230 x 100 x 300 mm



9250 29.103000  
300 x 100 x 250 mm

## SERIE 9400



## SERIE 9100



## ACCESSOIRES



**Druckerei  
Müllerleile**

Weitere Sonderartikel finden Sie bei:  
Robert Müllerleile GmbH & Co.  
Postfach 1880 · D-77908 Lahr  
Tel. +49 7821 9079-0  
Fax +49 7821 9079-79  
E-Mail: info@muellerleile.de  
www.muellerleile.de

# SERIE 8002 GLOSSY



8002 60

8002 61



8002 03



8002 02



8002 01



8002 42



8002 12



8002 11



8002 10



8002 41



8002 22



8002 21





8025 15



8025 13



8025 01



8025 09



8025 05



8025 10



8025 06



8025 12



8025 18



8025 20



8000 63



8000 08



8000 09



8000 24



8000 25



8000 06

FARBEN COLOURS COULEURS COLORES

DEKO-SYSTEME DECO SYSTEMS SYSTÈMES DÉCORATIFS SISTEMAS DE DECORACIÓN

ROMA



TOP SOFT



# SERIE 8010 CLASSIC



# SERIE 8110 RING



# SERIE 8080 PRICE SYSTEM



BASIC

8030 75 ①  
8030 76 ②  
8030 77 ③  
8030 78 ④  
300 x 130 x 415 mm



8030 70 ①  
8030 71 ②  
8030 72 ③  
8030 73 ④  
240 x 110 x 315 mm



8040 04

DOME



8030 01 ①  
8030 02 ②  
300 x 70 x 320 mm

BOARD



8030 40 ①  
8030 41 ②  
8030 42 ③  
8030 43 ④  
170 x 115 x 395 mm



8040 03

SWING



8030 80 ①  
8030 81 ②  
8030 82 ①  
8030 83 ②  
8030 84 ①  
8030 85 ②  
310 x 208 x 310 mm



8040 02



8040 01

- ① Standard · standard · standard · estándar
- ② Preishalter für DELTA-Ziffern · price holders for DELTA-numbers · support prix pour chiffres DELTA · soportes numeraciones DELTA
- ③ Öffnungen für Preisetiketten · holes for price tags · ouverture pour support prix · aberturas vpara etiquetas
- ④ Preishalter für DELTA-Ziffern und Öffnungen für Preisetiketten · price holders for DELTA-numbers and holes for price tags · support prix et support pour chiffres DELTA · soportes numeraciones DELTA y aberturas para etiquetas

# SERIE 8045 TRAY SYSTEM



## Vorlagetablets tray | plateau carré | bandeja

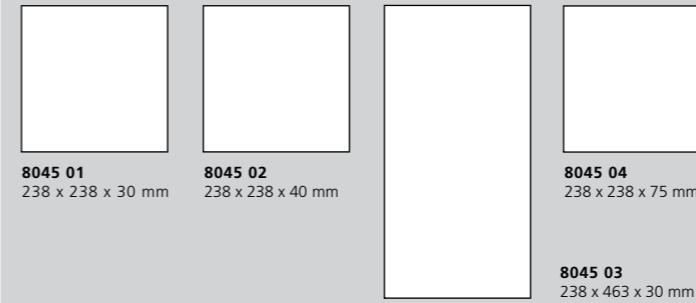

## Tiefzieheinlage vacuum formed insert | intérieur thermo | interior termoformado

## Kartusche pad | intérieur | almohadilla

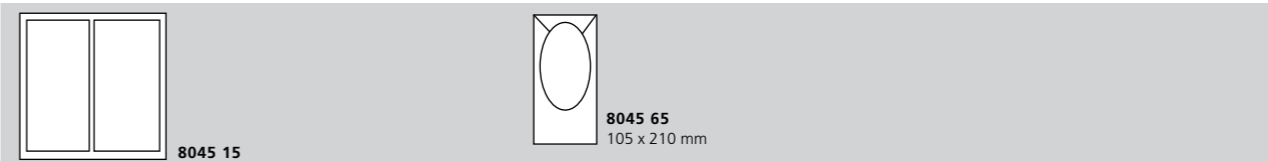
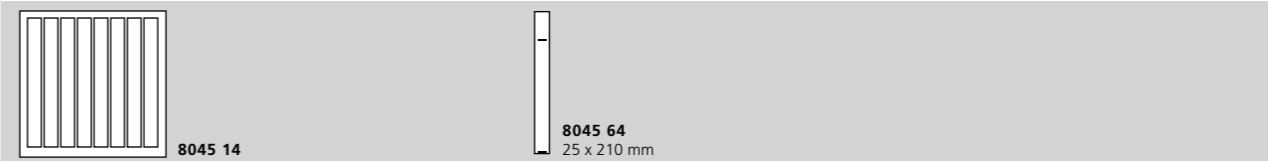
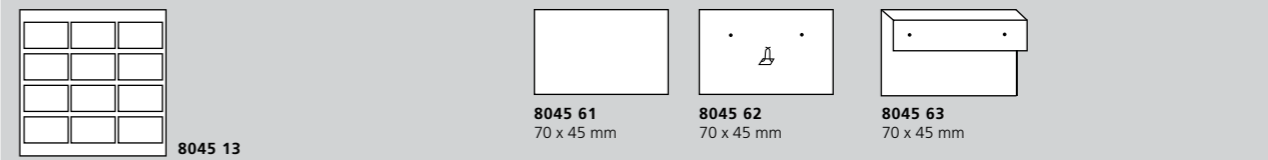
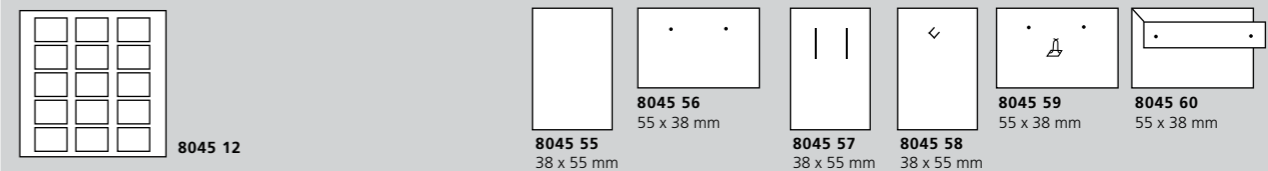
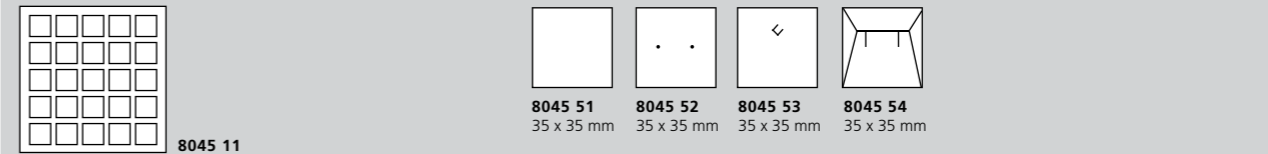

## Einlage insert | intérieur | interior

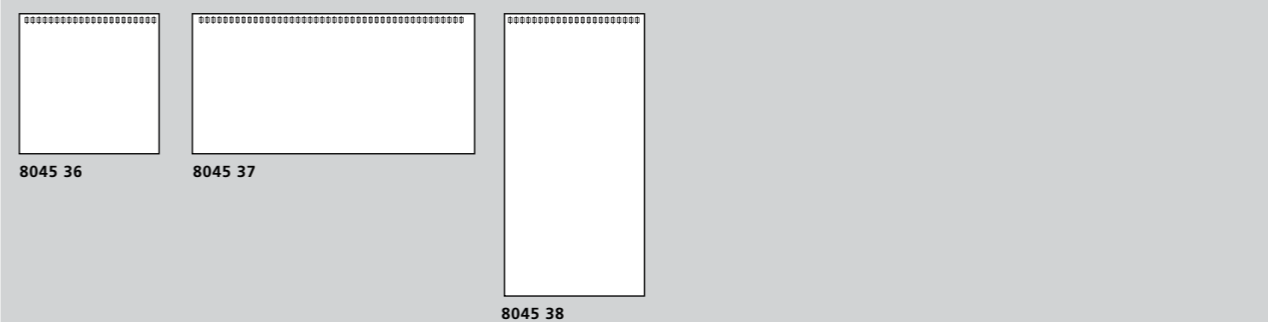
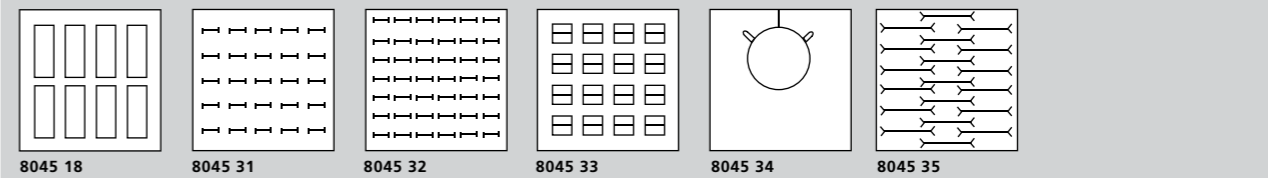



# SERIE 8900–8903 VARIANT

Fragen Sie nach unserer Farbkarte.  
Please ask for our special colour chart.

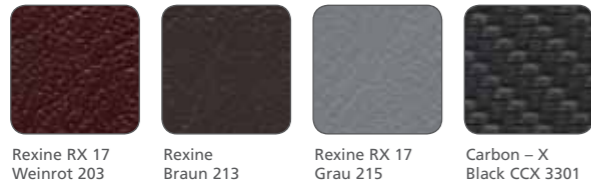
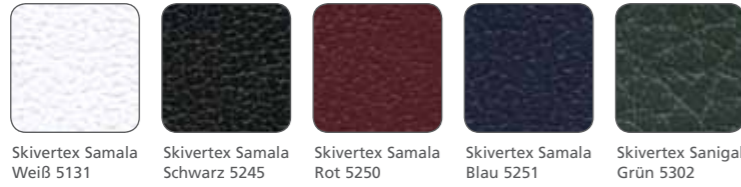

**NEW**



ECO  
Schaumstoffeinlage  
Foam pads  
Cousinette flockage  
Interiores espuma

## Variant-Programm: Die Schubladen-Elemente | The drawer systems

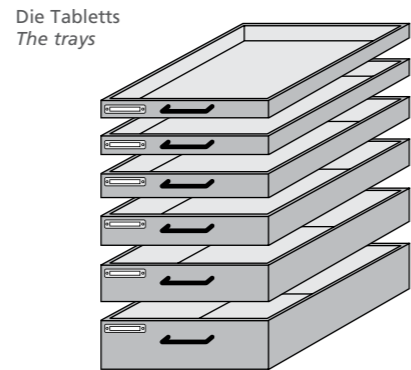
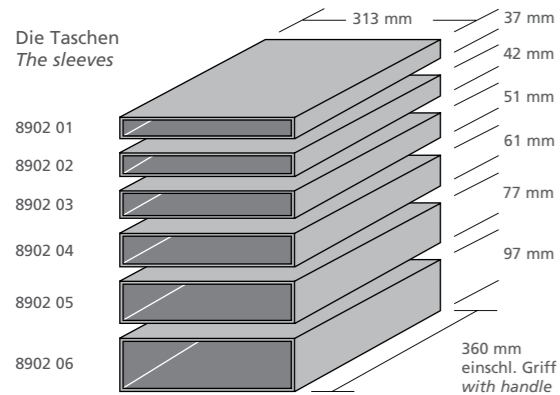

## Einrichtungs-Varianten | Furnishing variants

<p><b>8900 01, 37 mm</b> Universal flach, mit 3 losen Trennwänden tray universal, flat, with 3 loose dividers</p>	<p><b>8900 03, 51 mm</b> 8900 04, 61 mm Universal leer mit Filztuch tray universal, empty, with felt cloth</p>	<p><b>8900 05, 37 mm</b> Universal flach mit Plexinut-leisten, 3 losen Trennstäben tray universal, flat, with acrylic stripes and 3 loose dividers</p>	<p><b>8900 07, 37 mm</b> 7 HAU lang, Universalfächer tray with 7 compartments for gent's watch long</p>	<p><b>8900 08, 42 mm</b> 7 HAU lang, Universalfächer hoch tray with 7 high compartments for gent's watch long</p>	<p><b>8900 09, 42 mm</b> 14 HAU kurz, Universalfächer tray with 14 compartments for gent's watch short</p>	<p><b>8900 10, 37 mm</b> 15 DAU, Universalfächer tray with 15 compartments for ladies' watch</p>
<p><b>8900 02, 51 mm</b> Universal hoch, mit 3 losen Trennstäben tray universal, high, with 3 loose dividers</p>	<p><b>8900 11, 42 mm</b> 11 DAU lang Universalfächer hoch tray with 11 compartments for ladies' watch long</p>	<p><b>8900 12, 77 mm</b> 15 DAU mit Spange tray for 15 ladies watches, with watchsprings</p>	<p><b>8900 14, 77 mm</b> 12 HAU mit Spange tray for 12 gent's watches, with watchsprings</p>	<p><b>8900 17, 97 mm</b> 48 Armreife, Plexinutleisten mit 48 losen Trennstäben tray for 48 bangles, with acrylic stripes and 48 loose dividers</p>	<p><b>8900 20, 37 mm</b> 20 Taschenuhren, Universalfächer tray for 20 pocket watches, universal compartments</p>	<p><b>8900 21, 37 mm</b> 36 Münzen, Universalfächer tray with 36 coins, universal compartments</p>
<p><b>8900 22, 37 mm</b> 72 Anhänger, Universalfächer tray for 72 pendants, universal compartments</p>	<p><b>8900 25, 51 mm</b> 78 Ringe versetzt tray for 78 rings, shifted</p>	<p><b>8900 26, 61 mm</b> 56 Ringe versetzt, 2 lose Tablett à 28 Ringe tray for 56 rings, shifted, 2 loose inlets for 28 rings each</p>	<p><b>8900 27, 61 mm</b> 48 Ringe mit Büschung, 2 lose Tablett à 24 Ringe tray for 48 rings in cushions, 2 loose inlets for 24 rings each</p>	<p><b>8900 28, 61 mm</b> 48 Ringe mit Büschung, 4 lose Tablett à 12 Ringe tray for 48 rings in cushions, 4 loose inlets for 12 rings each</p>	<p><b>8900 29, 61 mm</b> 30 Ringe mit Büschung, 2 lose Tablett à 15 Ringe tray for 30 rings in cushions, 2 loose inlets for 15 rings each</p>	<p><b>8900 30, 61 mm</b> 24 Ringe mit Büschung, 4 lose Tablett à 6 Ringe tray for 24 rings in cushions, 4 loose inlets for 6 rings each</p>
<p><b>8900 31, 37 mm</b> 56 Kartuschenfächer (35x35), Universalfächer tiefgezogen tray with 56 universal compartments (vacuum formed)</p>	<p><b>8900 32, 37 mm</b> 36 Kartuschenfächer (38x50), Universalfächer tiefgezogen tray with 36 universal compartments (vacuum formed)</p>	<p><b>8900 33, 37 mm</b> 30 Kartuschenfächer (38x55), Universalfächer tiefgezogen tray with 30 universal compartments (vacuum formed)</p>	<p><b>8900 34, 37 mm</b> 18 Kartuschenfächer (75x50), Universalfächer tiefgezogen tray with 18 universal compartments (vacuum formed)</p>	<p><b>8900 35, 51 mm</b> 48 Trauringe mit Polster, 2 lose Tablett à 24 Paar Trauringe trays for 48 wedding rings in cushions, 2 loose inlets for 24 pairs of wedding rings</p>	<p><b>8900 37, 42 mm</b> 25 Universalkartuschen, Universalfächer tray with 25 universal compart., 25 universal pads included</p>	<p><b>8900 38, 42 mm</b> 25 Collier-Anhängerkartuschen, Universalfächer tray with 25 universal compart., 25 pads for necklace pend. included</p>
<p><b>8900 39, 51 mm</b> 36 Ohrringkartuschen, Universalfächer tray with 36 universal compart., 36 pads for earrings included</p>	<p><b>8900 41, 51 mm</b> 22 Perketten, mit Tasche und Klappe tray for 22 pearl necklaces, with pocket and lateral flaps</p>	<p><b>8900 42, 51 mm</b> 10 Colliers, gebogene Fächer mit Tasche und Klappe tray for necklaces in curved compartments with pocket and flap</p>	<p><b>8900 43, 97 mm</b> 16 Colliers, 4 Platten übereinander à 4 Colliers tray for 16 necklaces with 4 inlets for 4 necklaces each to be stacked</p>	<p><b>8900 44, 42 mm</b> 4 Colliers, 4 Platten à 1 Collier tray for 4 necklaces with 4 inlets for 1 necklace each</p>	<p><b>8900 45, 37 mm</b> 24 Collierkettchen quer, Hakenleiste mit Tasche tray for 24 chains, transversal row of hooks and opposite pocket</p>	<p><b>8900 47, 97 mm</b> 500 Collierkettchen in 11 Fächern quer, Hakenleiste an Balken tray for 500 chains in 11 transv. pockets, row of hooks on bars</p>
<p><b>8900 46, 37 mm</b> 28 Collierkettchen längs, Hakenleiste ohne Tasche tray for 28 chains, lengthwise row of hooks, no opposite pocket</p>	<p><b>8900 49, 77 mm</b> 144 Tierkreiszeichen- kartuschen, 12 lose Tablett à 12 Fächer tray with 144 pads f. charms, in 12 loose inlet stackable with 12 univ. compar. each</p>					

# SERIE 8910-12 COMBI-NORM



Fragen Sie nach unserer Farbkarte.  
Please ask for our special colour chart.



## Combi-Norm-System: Maße und Kombinationen | Combi-Norm-System: Measurements and Combinations

Kettenblocks  
Chain blocks

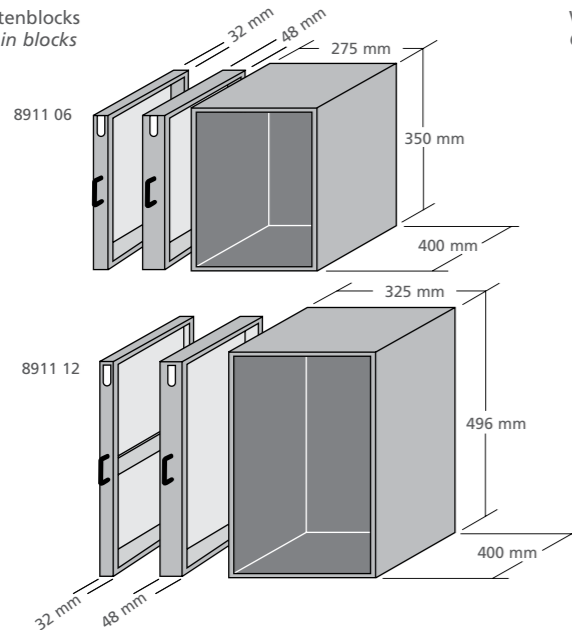

Warenblock (individuell kombinierbar)  
Combi-Norm-Block (to be combined individually)

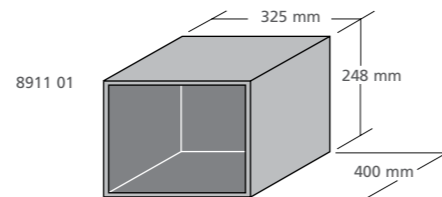

Die Schubladen  
The drawers

Die Gesamthöhe der Schubladen muss immer 224 mm ergeben.  
The Norm block is only complete when the addition exactly sums up to 224 mm.

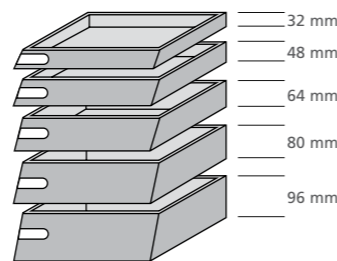

## Einrichtungs-Varianten | Furnishing variants

<b>8910 10, 32 mm</b> <b>8910 11, 48 mm</b> <b>8910 12, 64 mm</b> <b>8910 13, 80 mm</b> Universal drawer universal	<b>8910 14, 32 mm</b> Universal mit Plexinut- leisten, 7 lose Trennstäbe drawer universal, with acrylic stripes and 7 loose dividers	<b>8912 20</b> Tablett à 36 Ringe mit Ringwulst inlet for 36 rings in puff cushions	<b>8912 21</b> Tablett à 24 Ringe mit Büschung inlet for 24 rings in cushions	<b>8912 22</b> Tablett à 8 Ringe mit Rhombusbüschung inlet for 8 rings in rhombus cushions	<b>8912 23</b> Tablett à 24 P.-Ringe mit Trauringbüschung inlet for 24 pairs of wedding rings in cushions	<b>8912 25</b> Tablett à 14 Ringe mit Rhombusbüschung inlet for 14 rings in rhombus cushions	<b>8910 31, 32 mm</b> 16 DAU, Universalfächer drawer for 16 ladies watches in universal compartments
<b>8910 32, 32 mm</b> 21 DAU, Universalfächer drawer for 21 ladies watches in universal compartments	<b>8910 33, 48 mm</b> 16 HAU kurz, Universalfächer drawer for 16 gent's watches short in universal compartments	<b>8910 34, 32 mm</b> 8 HAU lang, Universalfächer drawer for 8 gent's watches long in universal compartments	<b>8910 36, 80 mm</b> 15 DAU mit Spange drawer for 15 ladies watches on loose springs	<b>8910 37, 80 mm</b> 12 HAU mit Spange drawer for 12 gent's watches on loose springs	<b>8910 40, 32 mm</b> 12 Kartuschenfächer (90x85), Universalfächer drawer with 12 compartments	<b>8910 41, 32 mm</b> 18 Kartuschenfächer (75x50), Universalfächer drawer with 18 compartments	<b>8910 42, 32 mm</b> 20 Kartuschenfächer (65x65), Universalfächer drawer with 20 compartments
<b>8910 43, 32 mm</b> 20 Kartuschenfächer (50x75), Universalfächer drawer with 20 compartments	<b>8910 44, 32 mm</b> 20 Kartuschenfächer (50x83), Universalfächer drawer with 20 compartments	<b>8910 45, 32 mm</b> 30 Kartuschenfächer (40x60), Universalfächer drawer with 30 compartments	<b>8910 50, 32 mm</b> 32 Kartuschenfächer (55x38), Universalfächer drawer with 32 compartments	<b>8910 51, 32 mm</b> 36 Kartuschenfächer (38x50), Universalfächer drawer with 36 compartments	<b>8910 52, 32 mm</b> 36 Kartuschenfächer (38x55), Universalfächer drawer with 36 compartments	<b>8910 53, 32 mm</b> 40 Kartuschenfächer (50x38), Universalfächer drawer with 40 compartments	<b>8910 54, 48 mm</b> 45 Kartuschenfächer (45x35), Universalfächer drawer with 45 compartments
<b>8910 55, 32 mm</b> 49 Kartuschenfächer (35x45), Universalfächer drawer with 49 compartments	<b>8910 56, 32 mm</b> 63 Kartuschenfächer (35x35), Universalfächer drawer with 63 compartments	<b>8910 60, 96 mm</b> 48 Armreife, mit Plexinutleisten 48 lose Trennstäben drawer for 48 bracelets, with acrylic stripes and 48 adjustable dividers	<b>8910 62, 32 mm</b> 24 Collierkettchen quer, Hakenleiste ohne Tasche drawer for 24 chains on row of hooks transversal, without pocket	<b>8910 64, 32 mm</b> 4 Colliers, 4 Platten à 1 Collier drawer for 4 necklaces on 4 removable pads	<b>8910 65, 32 mm</b> 30 Collierkettchen längs, Hakenleiste, ohne Tasche drawer for 30 chains on lengthwise row of hooks, without pocket	<b>8910 66, 48 mm</b> 14 Halsketten, Bogenfächer drawer with 14 curved compartments for necklaces	<b>8910 67, 48 mm</b> 17 Perlketten, Universalfächer drawer for 17 pearl necklaces

Passende Kartuschen siehe Preisliste Serie 8090 | For suitable pads see series 8090 in price list



LESER GmbH  
P.O. 2168 · D-77911 Lahr  
Phone: +49 7821 5803-0  
Fax: +49 7821 5803-70

[www.leser.de](http://www.leser.de)  
[leser@leser.de](mailto:leser@leser.de)



**Sprechen Sie uns an!**  
Contact us!  
Consultez nous!  
Favor contactarnos!

